

8 7 6 5 4 3 2 1

NOTES: UNLESS OTHERWISE SPECIFIED.

1. DIMENSIONS SHOWN ARE REFERENCE.
2. DIMENSIONS ARE IN cm.
3. USE MINIMUM OF 3 ANCHORS PER TRANSITION STRAP. UTILIZE HIGHEST AND LOWEST BOLT HOLE WHERE PRACTICAL.

ITEM	PART NO.	DESCRIPTION	QTY.
1	BSI-1808014-00	NOSE PLATE, ABSORB-M	1
2	BSI-1808006-00	ELEMENT ASSEMBLY, ABSORB-M	3
3	BSI-1808005-00	PIN ASSEMBLY, ABSORB-M	10
4	BSI-1809035-00	MIDNOSE, GALVANIZED, ABSORB-M	1
5	BSI-1809036-00	TRANSITION, GALVNIZED	1
6	BSI-1809037-00	TRANSITION STRAP LH, GALVANIZED, ABSORB-M	1
7	BSI-1809038-00	TRANSITION STRAP RH, GALVANIZING, ABSORB-M	1
8	BSI-2002001	Anc Mech 5/8-11x6 Gal	6

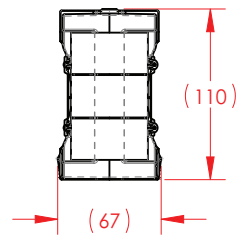
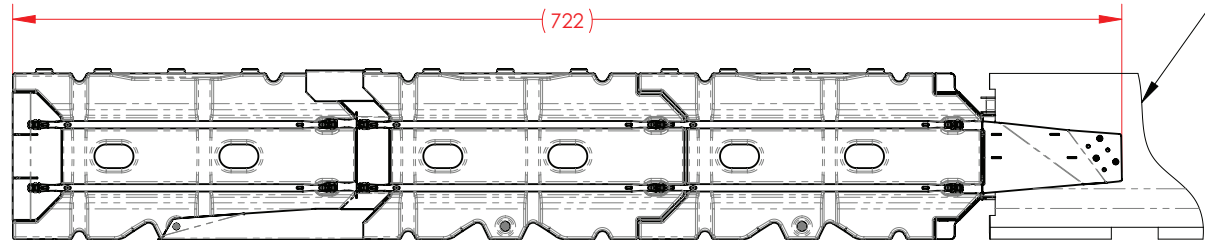
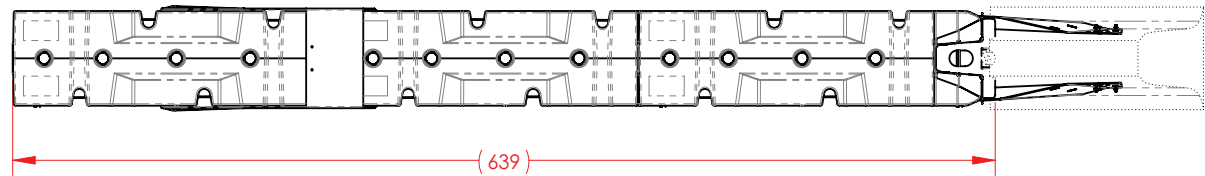

11/12/2020	(A) UPDATE DESCRIPTION FOR UP TO 80km/h	60080	NDP	TJH
3/20/2020	(1)	AP01515	JMT	GAD
REV DATE	REVISION	ECN	BY	APP

THE INFORMATION CONTAINED IN THIS DOCUMENT IS LINDSAY PROPRIETARY INFORMATION AND SHALL NOT BE REPRODUCED OR USED FOR ANY PURPOSE NOR DISCLOSED TO THIRD PARTIES WITHOUT THE WRITTEN APPROVAL OF LINDSAY.

WATERMARK Released		PART NUMBER BSI-2003107-AP	SHEET 1 OF 2
DO NOT SCALE DRAWING			METRIC
UNLESS OTHERWISE SPECIFIED DIMENSIONS ARE IN mm			
TOLERANCE: X = ±2 X.X = ±1.0 X.XX = ±0.25 X.X° = ±2° REMOVE ALL BURRS AND SHARP CORNERS		SCALE 1:32	DESCRIPTION ABSORB-M THREE ELEMENT SYSTEM, UP TO 80km/h (AUSTRALIA) MATERIAL - FINISH -
		REV: A	

8 7 6 5 4 3 2 1

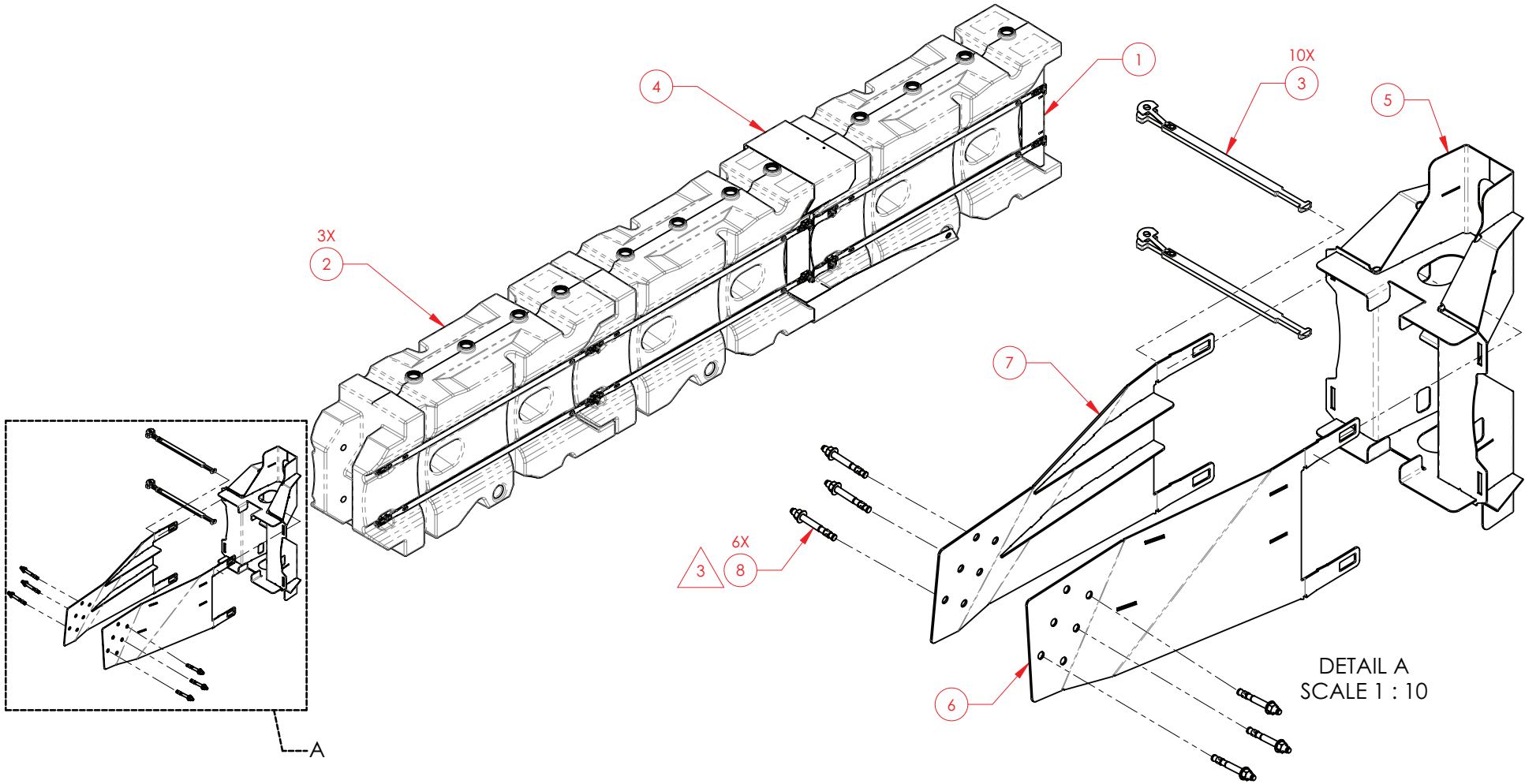



DETAIL A
SCALE 1 : 10

11/12/2020	(A) UPDATE DESCRIPTION FOR UP TO 80km/h	60080	NDP	T.JH
3/20/2020	(1)	AP01515	JMT	GAD
REV DATE	REVISION	ECN	BY	APP

THE INFORMATION CONTAINED IN THIS DOCUMENT IS LINDSAY PROPRIETARY INFORMATION AND SHALL NOT BE REPRODUCED OR USED FOR ANY PURPOSE NOR DISCLOSED TO THIRD PARTIES WITHOUT THE WRITTEN APPROVAL OF LINDSAY.

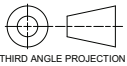

WATERMARK Released	PART NUMBER BSI-2003107-AP	SHEET 2 OF 2
	DESCRIPTION ABSORB-M THREE ELEMENT SYSTEM, UP TO 80km/h (AUSTRALIA)	
DO NOT SCALE DRAWING UNLESS OTHERWISE SPECIFIED DIMENSIONS ARE IN mm	METRIC  THIRD ANGLE PROJECTION	MATERIAL -
TOLERANCE: X = ±2 X.X = ±1.0 X.XX = ±0.25 X.X* = ±2* REMOVE ALL BURRS AND SHARP CORNERS	QR CODE 	FINISH -
SCALE 1:25	REV: A	