

PART/DRAWING	DESCRIPTION	QTY
P130G	ACP SENTRY BARRIER TL-4 POST 2000mm LONG	2
FW002	ACP SENTRY THRIE BEAM WASHER	4
F1002	M16x32 SPLICE BOLT AND NUT FOR RAIL CONNECTION	24
F1640	M16x40 POST BOLT AND OVERSIZED NUT	4
T200G	4.0M STANDARD THRIE-BEAM	2

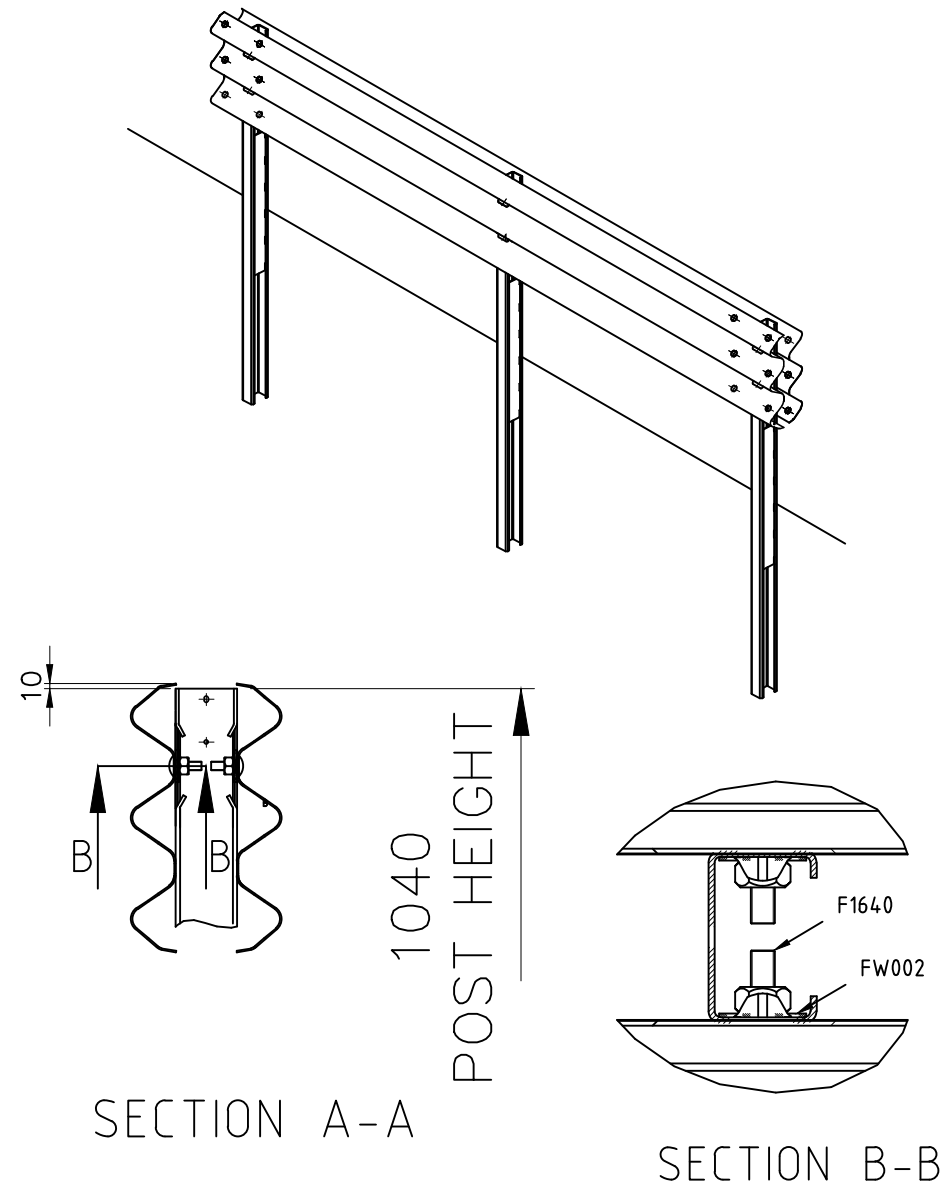
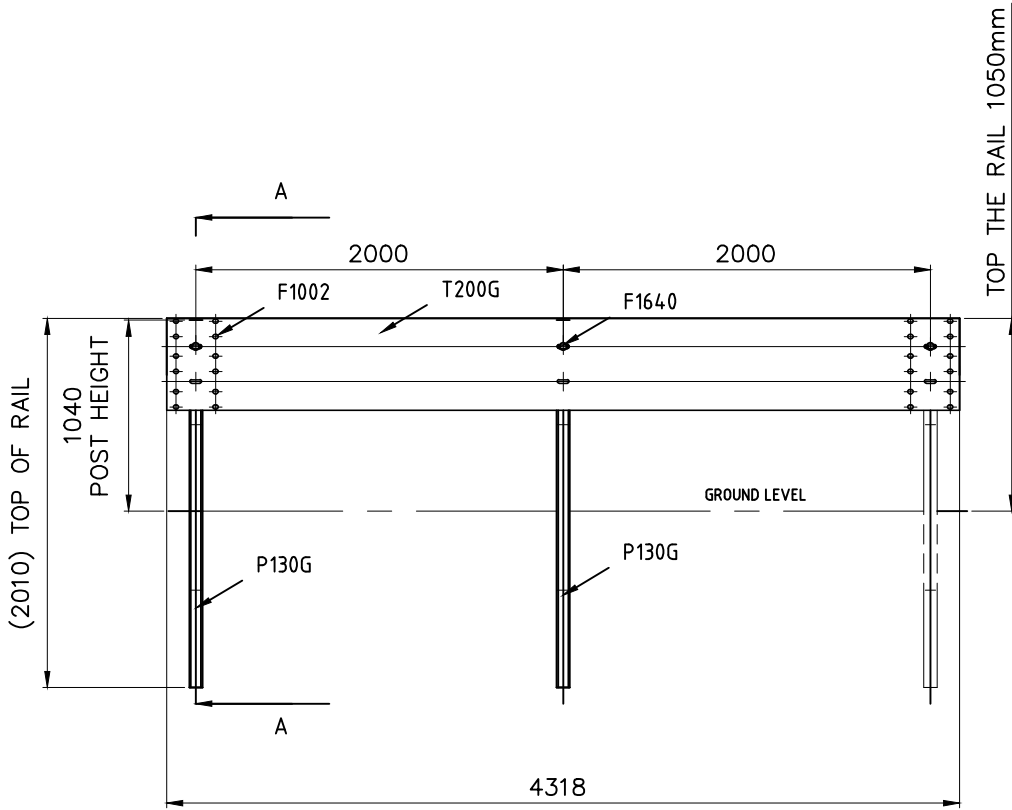

REV	DESCRIPTION	APPD	DATE
B	SECTION B-B CORRECTED	W.R.	05.06.23
A	ORIGINAL ISSUE	E.A.	17.02.23

ACP
 AUSTRALIAN CONSTRUCTION PRODUCTS
 Australian Construction Products Pty Ltd
 339 Horsley Road Milperra NSW 2214
 P.O. Box 565 Panania NSW 2213
 Tel: +61 2 9772 4172 Fax: +61 2 9792 6272

TOLERANCES
Whole Numbers ±2
One Decimal Place :±0.05
Bend Angle : ±2
Straightness : 1.5per1500
Scale: N.T.S.

CLIENT
MATERIAL STEEL TO AS/NZS 1594
FINISH PRETREATMENT TO AS 1627 HOT DIP GALVANISE TO AS/NZS 4680

ITEM ACP SENTRY MEDIAN BARRIER TL-4 THRIE BEAM SYSTEM		
DRAWING NUMBER GA099		
DRAWN E.A.	CHECKED	APPROVED